

## COMBINED HUMIDITY AND TEMPERATURE SENSOR



### TECHNICAL DATA

Model Number	Permissible Temperature range	Protection class	Sensor Head, mm	Sensor Post, mm
DCV-HT-MFTG-100V	-40°C to +60°C	IP65	80W x 80H x 37D	Ø12 x 82

### DESCRIPTION

Can provide accurate measurement of both relative humidity and temperature in air conditioned and refrigerated conditions. The sensing element contains a special protective coating for use in polluted environments.

#### Features

- Relative humidity measurement range: 0-100%.
- The temperature measurement is made by the change in resistance on the built-in PTC (Positive Temperature Coefficient) element (KTY81-210).
- High grade sintered stainless steel element acts as a filter against contaminants.

### WIRING DIAGRAM

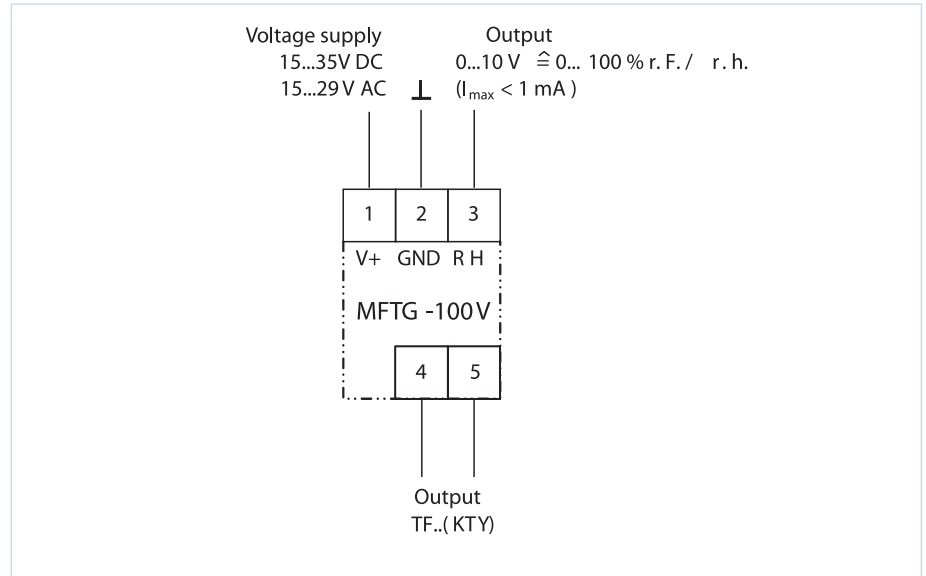

## COMBINED CO<sub>2</sub>, HUMIDITY AND TEMPERATURE SENSOR



### TECHNICAL DATA

Model Number	Protection class	Sensor Head, mm
DCV-CB-MCFTG-3AV	IP20	80W x 100H x 26D

### DESCRIPTION

A combined sensor designed to measure CO<sub>2</sub> concentration, relative humidity and temperature. Typical applications include occupied spaces such as office buildings, conference rooms and education centres. Measurements can be taken either separately or combined.

#### Features

- Values are shown alternatively on an integrated display.
- Measurement range:
  - CO<sub>2</sub>: 0-2000 ppm
  - Humidity: 0-100%
  - Temperature: 0°C to +50 °C
- 24V AC  $\pm$ 20 %

### WIRING DIAGRAM

