

DIMENSIONS & SELECTION TABLES

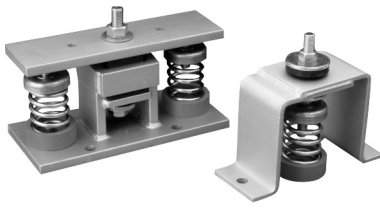

FEATURES

Seismic mounts should be used in locations where earthquakes or seismic disturbances are considered to be a potential hazard. Seismic restraint is specified in AS1170.4 and NZS4219.

Features include:-

- Rugged fabricated steel construction
- Heavy duty stable steel spring
- Acoustic isolation pad
- Single fully adjustable central vertical restraint bolt
- Fully weatherproofed

The seismic mounts shown here cover most fan applications, i.e. 25mm deflection and light to medium duty applications. Details of our complete range of seismic mountings are available on request.

Full load capacities & static deflections

CSM - refer to XSB spring mounts

CLM - refer to XL spring mounts

CWM - refer to Fantech for XW spring mount data.

HOW TO ORDER

The selection of mounts for use in seismic applications is complex and should be referred to our Sales Engineers.

It is the customers responsibility to provide the 'static restraint capacity' required and should be checked against relevant standard or engineering specifications.

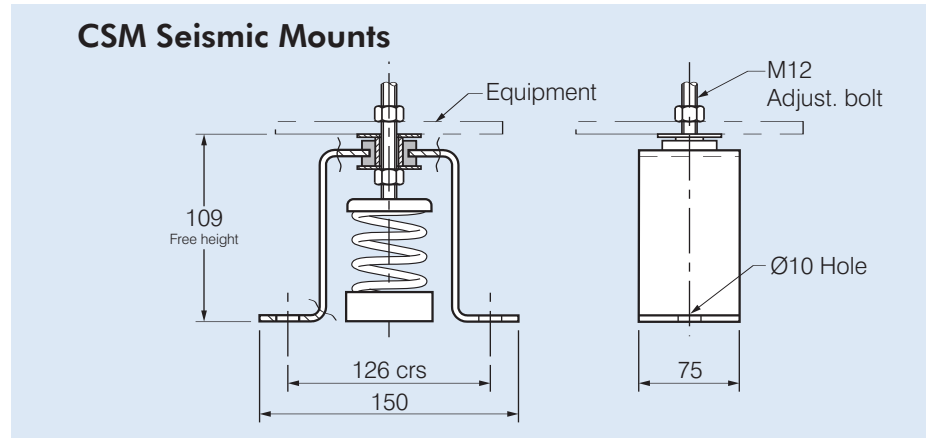

Model Number	Load Range, kg	Nominal Defl. mm	Static Restraint Capacity	
			Horizontal, kN	Vertical, kN
CSM-9 to 17	10-200	25	1.0	2.0

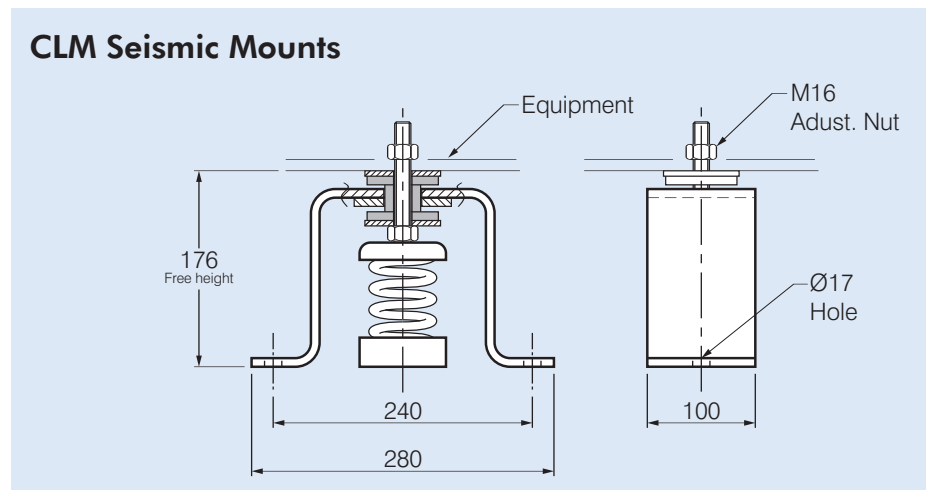

Model Number	Load Range, kg	Nominal Defl. mm	Static Restraint Capacity	
			Horizontal, kN	Vertical, kN
CLM-89 to 100	10-650	25	3.5	7.0

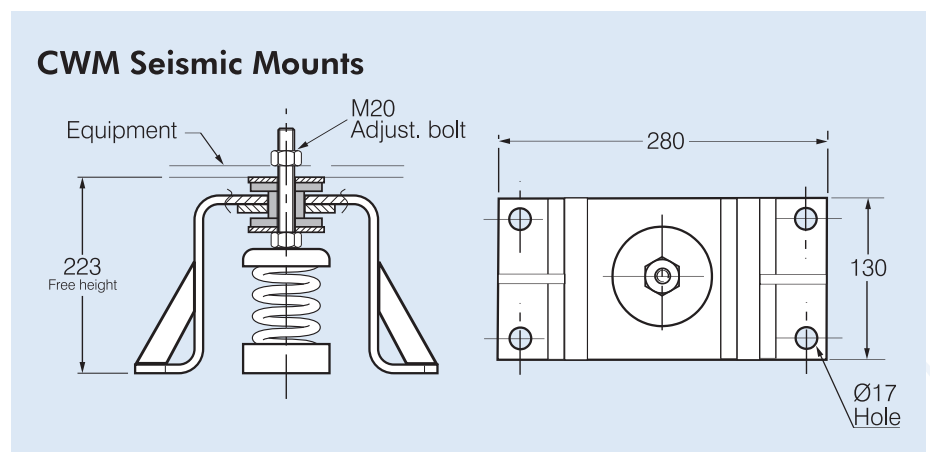

Model Number	Load Range, kg	Nominal Defl. mm	Static Restraint Capacity	
			Horiz. kN	Vert. kN
CWM	300-1275	25	6	12